

IBIS®



CREAM COOKERS

CREAM COOKERS

Cream cookers manufactured by IBIS are ideal machines for all-round pastry and bakery production. The devices are also used in catering facilities, hotel kitchens or restaurants.

Using the machine, you can, for example, brew flour, poppy seeds or sunflower seeds. In addition, it is possible to cook pudding, vegetables, soups and jellies in the machine. The cream cooker can also melt chocolate. What's more, you can prepare steamed cake, jams and preserves, stuffing, tiramisu mass and chocolate mass. The brewers are very durable machines, and the elements in contact with the food product are made of high-quality acid-resistant steel.

Manufactured in accordance with the applicable CE standards, applying the latest health and safety standards. An important element of the cream cooker is the control panel. A clear and easy-to-use desktop, digital temperature controller, as well as a convenient tank tilting mechanism significantly improve the comfort of using the cream machine. A practical solution is the inspection built-in hopper in the tank lid, which allows you to control the entire process and to add ingredients during machine operation without stopping it.

Available devices with tanks with a capacity of:

30, 60, 80, 120 and 200 liters.



Clear and easy to use control panel

All elements coming in direct contact with food are made of high quality acid-proof steel

Comfortable operation thanks to tilting tank which makes it easier to remove the content and clean the machine

Mixing tool equipped with scrapers which clean bottom and side of the tank

A drain valve installed at the bottom of the tank (option)
K120, K200 - drain valve in standard

Smooth speed control of the mixing tool (inverter)

Quick assembly of mixing tool

Tank lid with the built-in hopper for monitoring of the process and for admixing ingredients during operation

Double tank made of high quality stainless INOX steel

Solid structure, machine body painted in white (option: INOX steel)

Leveling feet ensure the stability of the device during operation (option: wheels)

**MAXIMUM
TEMPERATURE
UP TO 150°C**

CREAM COOKER K80



BREWING:

- flour
- poppies
- sunflower seeds etc.

COOKING:

- pudding
- jellies
- vegetables
- soups

PREPARATION OF:

- brewed dough
- jams
- stuffing
- chocolate
- tiramisu mass

MELTING:

- chocolate
- pomades



FLAT BEATER



DOUBLE MIXING TOOL



WATCH THE VIDEO



A DO KREMOW
CREAM COOKERS
K 200



CREAM COOKER K200
WITH DRAIN VALVE



DRAIN VALVE



**INSPECTION
BUILT-IN HOPPER**

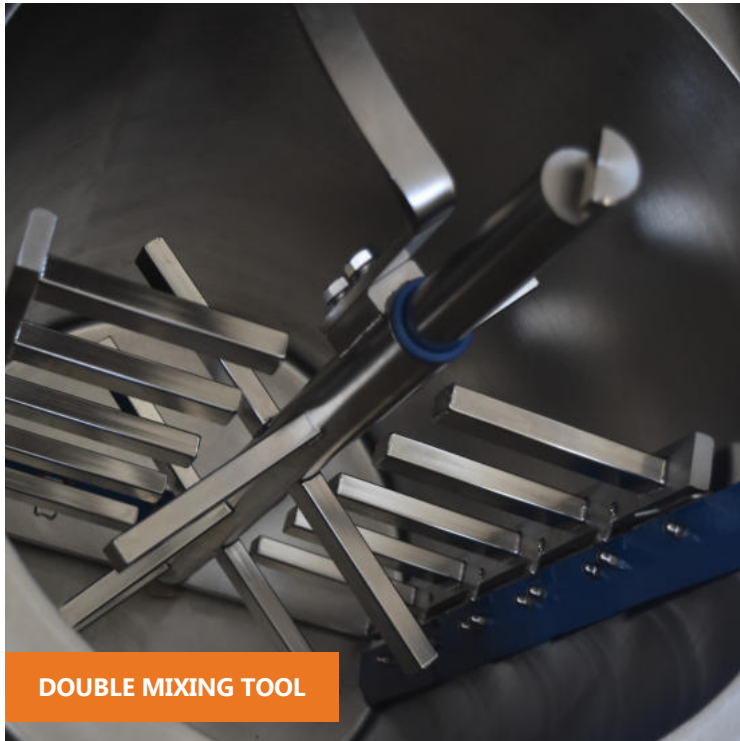

DOUBLE MIXING TOOL

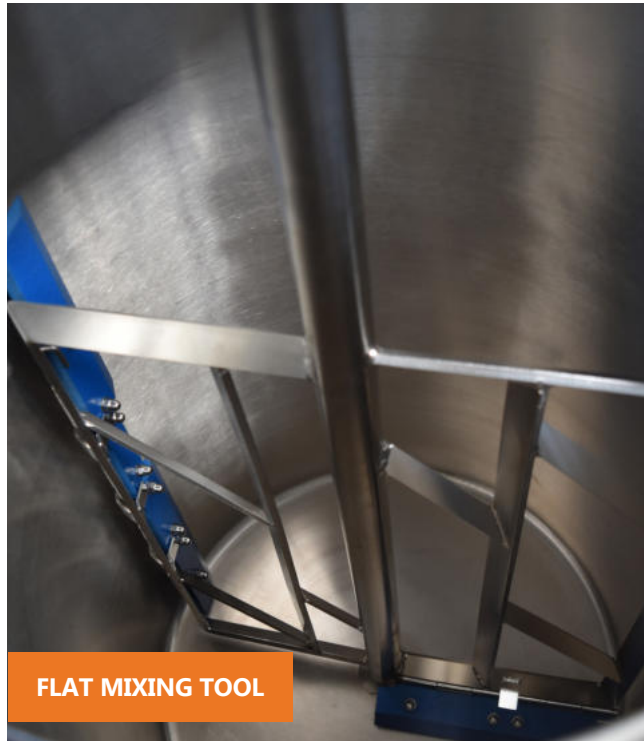

FLAT MIXING TOOL

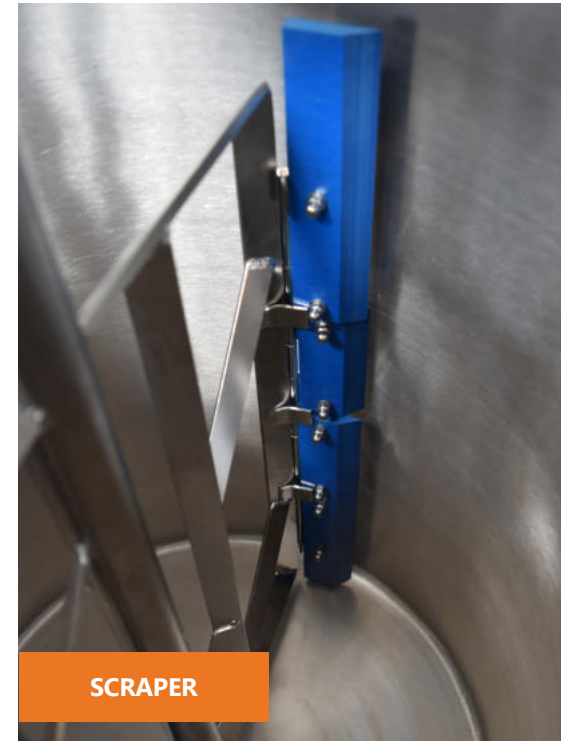

SCRAPER



TECHNICAL PARAMETERS

Model		K30	K60	K80	K120	K200
Tank capacity	l	30	60	80	120	200
Oil volume	l	10,5	17,5	21	29	42
Voltage	V	400	400	400	400	400
Heaters power	kW	4	6	9	15	18
Engine power	kW	0,55	0,75	1,1	1,5	2,2
Weight	kg	150	170	185	255	355



CREAM COOKER K80 INOX VESION WITH DRAIN VALVE

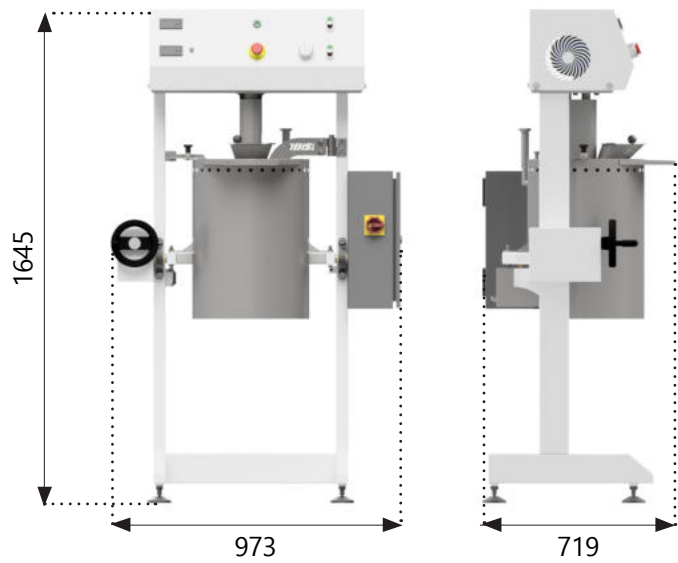

Cream cooker K30

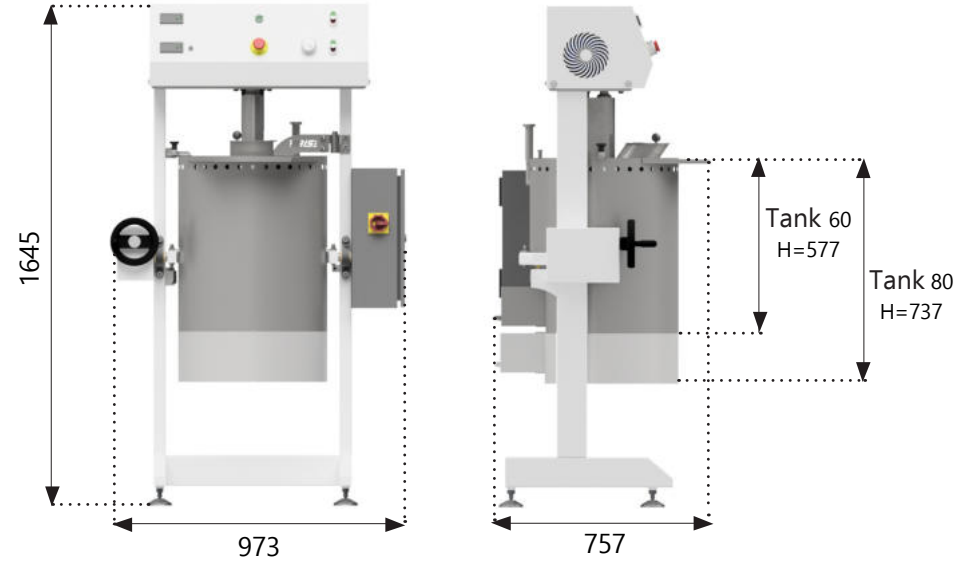

Cream cooker K60, K80

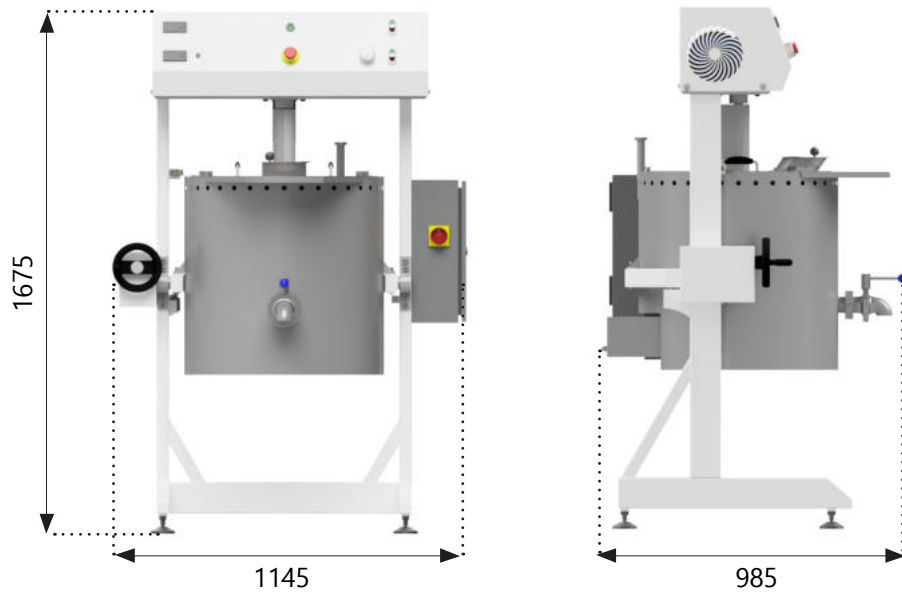

Cream cooker K120

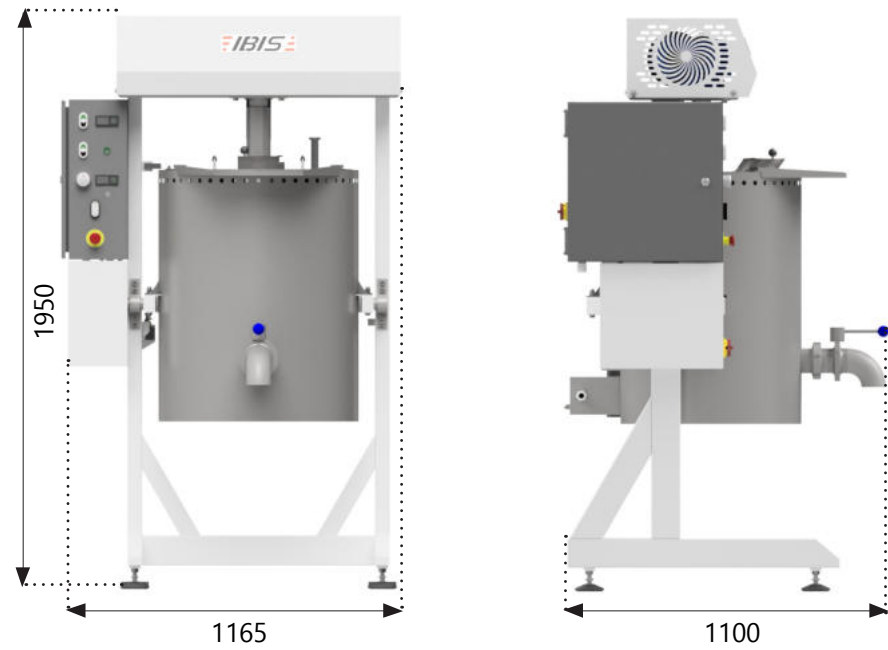

Cream cooker K200

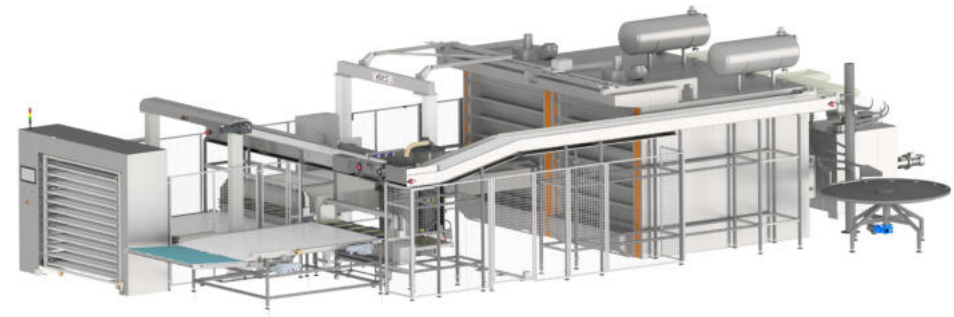
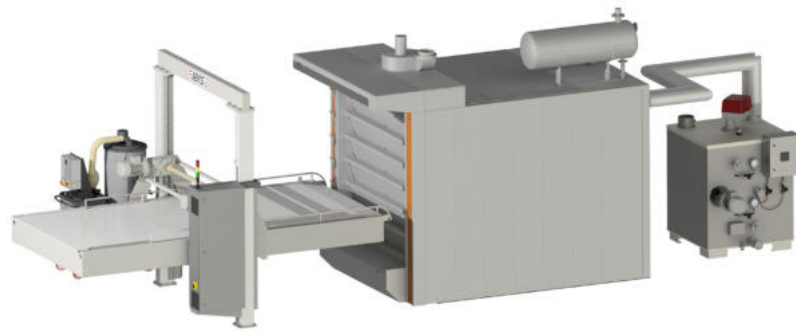

www.ibis.pl



IBIS Sp. z o.o.
ul. Jana Pawła II 38
89-200 Szubin
Poland

+48 52 391 02 00
+48 690 696 866
export@ibis.pl

Product photos are for illustrative purposes only, hence the actual appearance of the products may differ from those presented in the photos.